



## Flame sensor SKU: DFR0076

From Robot Wiki



Flame sensor V2

### Contents

- [1 Introduction](#)
- [2 Specification](#)
- [3 Application](#)
- [4 Tutorial](#)
  - [4.1 Connection Diagram](#)
  - [4.2 Sample Code](#)
  - [4.3 Result](#)
- [5 FAQ](#)

### Introduction

The flame sensor can be used to detect fire or other wavelength at 760 nm ~ 1100 nm light. In the fire-fighting robot game, the flame plays an important role in the probe, which can be used as the robot's eyes to find fire source or football. It can make use of fire-fighting robots, soccer robots.

Flame sensor probe angle of 60 degrees, the special sensitivity of the flame spectrum, two M3 mounting holes to stabilize the module will not spin.

The flame sensor's operating temperature is -25 degrees Celsius to 85 degrees Celsius, in the course of the flame it should be noted that the probe distance from the flame should not be too close in order to avoid damage.

The new version of analog sensor port pin mapping has been changed as the following two features. Please check [the tips for changing sensor cable pin mapping](#) while using the I/O Expansion shield. We will continue to update. For the inconvenience caused, please understand.

## Specification

- Supply Voltage: 3.3V to 5V
- Detection range: 20cm (4.8V) ~ 100cm (1V)
- Rang of Spectral Bandwidth : 760nm to 1100nm
- Responsive time : 15us
- Interface: Analog
- Size:22x30mm

## Application

- Fire alarm
- Fire-fighting robot

## Tutorial

### Connection Diagram

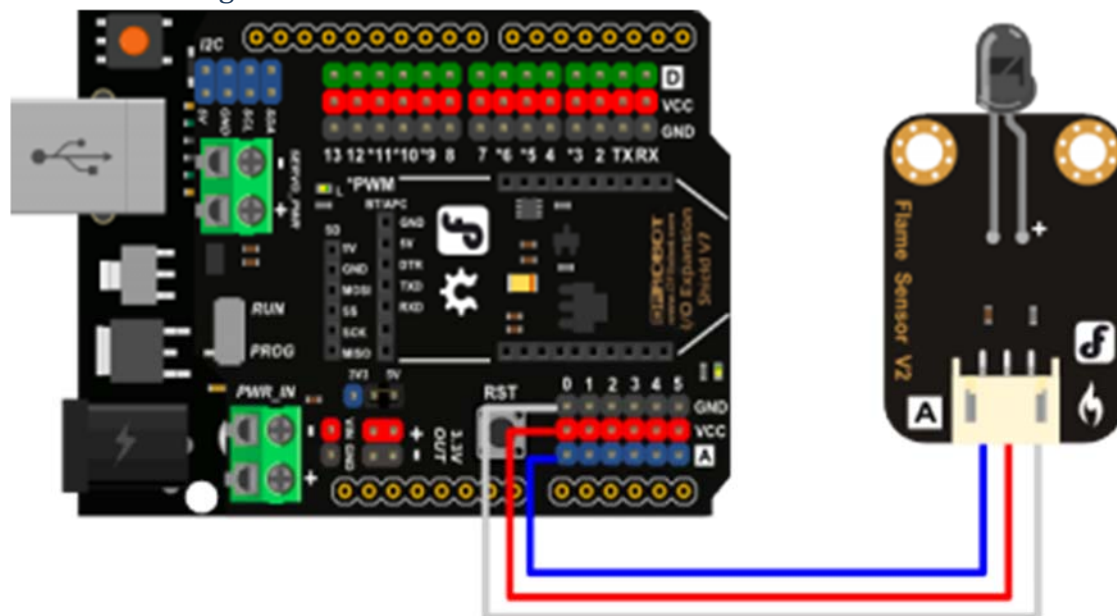

connection diagram

## Sample Code

```
/*
 # Product: Flame sensor
 # SKU    : DFR0076
 # Description:
 # When flame sensor detected flame, the data will be read by the serial.
*/

void setup() {
  Serial.begin(9600);
}

void loop() {
  int sensorValue = analogRead(A0);
  Serial.println(sensorValue);
}
```

## Result

When the flame sensor detects the flame in the numerical change can be observed in the serial monitor.

## FAQ

**Q1.** Some general Arduino Problems/ FAQ/ Tips, very good to know.

**A.** Click [the topic link](#) on DFRobot Forum.

**Q2.** Why my two flame sensors get different readings when to detect the same flame?

**A.** It's normal. As an analog sensor, the readings would be effected by flame intensity, flame position (angle & distance).

**Q3.** My flame sensor detects a flame without a flame present. At my desk it was reading values below 20, in my classroom students read value up to 800 without a flame present.

**A.** The range of Spectral Bandwidth of the sensor is: 760nm to 1100nm, so it would detect any light whose Spectral Bandwidth is within 760-1100nm. After test, we found it can be effected not only by flame, but also by **infrared radiation** (Analog read: 900), **neon lamps** in classrooms (Thanks to Richard) and it can even be effected by phone's flash (Analog read: 50). Generally, in our office, it outputs 0V (analog read: around 10). This can be found in its [datasheet](#).

For any question/advice/cool idea to share, please visit [DFRobot Forum](#).