



austriamicrosystems AG

is now

ams AG

The technical content of this austriamicrosystems application note is still valid.

Contact information:

Headquarters:

ams AG

Tobelbaderstrasse 30

8141 Unterpremstaetten, Austria

Tel: +43 (0) 3136 500 0

e-Mail: ams_sales@ams.com

Please visit our website at www.ams.com

AS5050 / AS5055

Programmable Magnetic Rotary Encoder

AS5050-AB-v1.1

Adapterboard

OPERATION MANUAL

1 VDD General Description

The AS5050/AS5055 is a single-chip magnetic rotary encoder IC with low voltage and low power features. It includes 4 integrated Hall elements, a high resolution ADC and a smart power management controller. The angle position, alarm bits and magnetic field information are transmitted over a standard 3-wire or 4-wire SPI interface to the host processor.

The absolute angle measurement provides instant indication of the magnet's angular position with a resolution of:

- AS5050: $0.35^\circ = 1024$ positions per revolution
- AS5055: $0.09^\circ = 4096$ positions per revolution

The AS5055 is available in a small QFN 16-pin 4x4x0.85mm package and specified over an operating temperature of -20 to +85°C.

2 The AS5050/AS5055 Adapter board

2.1 Board description

The AS5050/AS5055 adapter board is a simple circuit allowing test and evaluation of the AS5050/AS5055 rotary encoder quickly without building a test fixture or PCB.

The PCB can be attached to a microcontroller or to the AS5050/AS5055-DB Demoboard as external device.

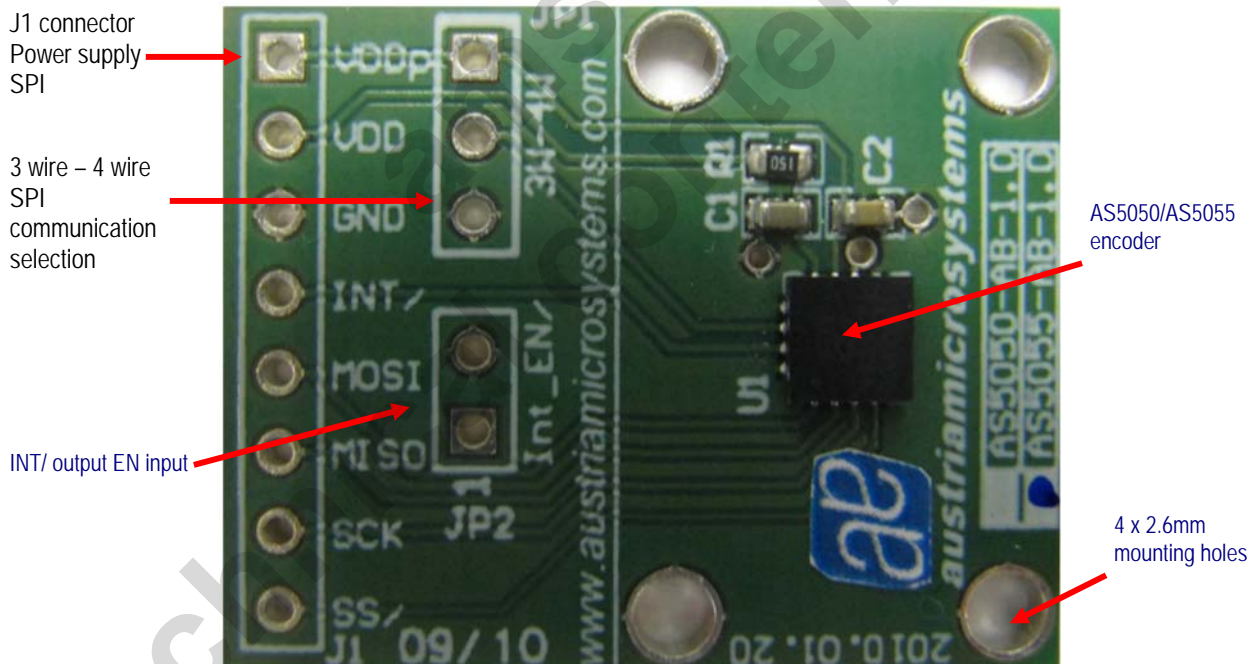

Figure 1: AS5050 Adapterboard

2.2 Mounting the AS5050 adapter board

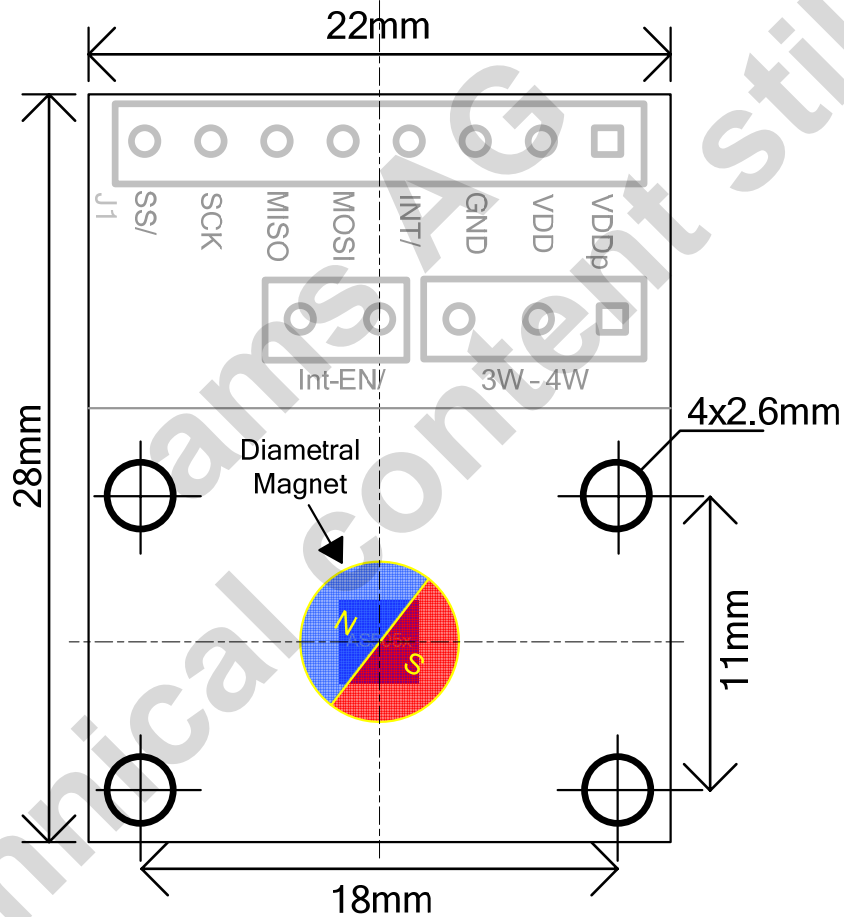
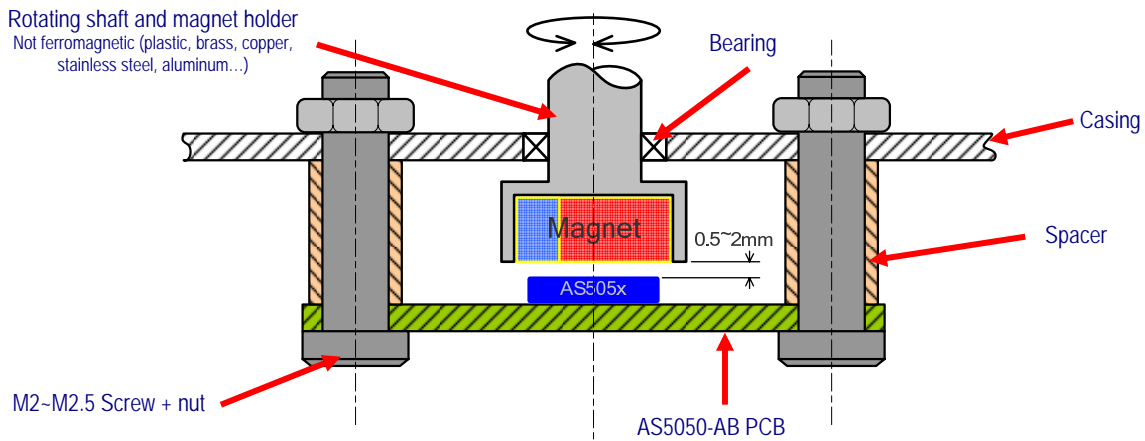

Figure 2: AS5050 adapter board mounting and dimension

A diametral magnet must be placed over on under the AS5050/AS5055 encoder, and should be centered on the middle of the package with a tolerance of 0.5mm.

The airgap between the magnet and the encoder casing should be maintained in the range 0.5mm~2mm.

The magnet holder must not be ferromagnetic. Materials as brass, copper, aluminum, stainless steel are the best choices to make this part.

3 AS5050/AS5055 and adapter board pinout

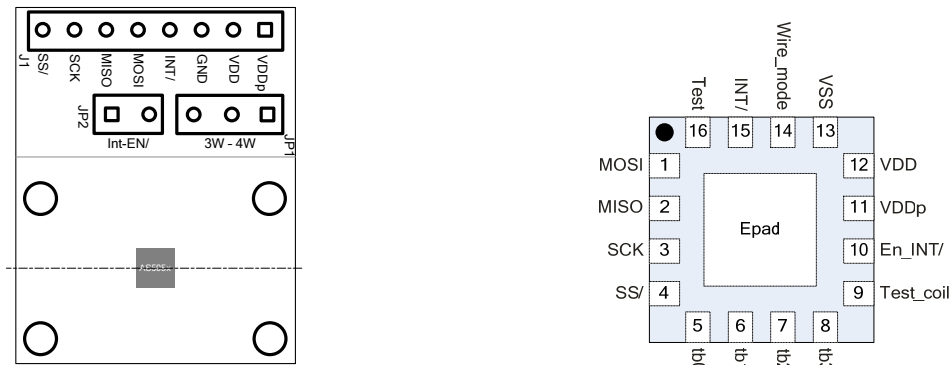

Figure 3: AS5050/AS5055 adapter board connectors and encoder pinout

| Pin# Board | Pin# AS5050/ AS5055 | Symbol Board | Type | Description |
|------------|---------------------|--------------|-------|---|
| J1 - 1 | 7 | VDDp | S | Peripheral power supply, 1.8V - VDD |
| J1 - 2 | 9 | VDD | S | Analog and digital power supply, 3.0 - 3.6V |
| J1 - 3 | 10 | GND | S | Supply ground |
| J1 - 4 | 11 | INT/ | DIO | Interrupt output. Active LOW, when conversion is finished |
| J1 - 5 | 15 | MOSI | DI | SPI bus data input |
| J1 - 6 | 16 | MISO | DO | SPI bus data output |
| J1 - 7 | 8 | SCK | DI_PD | SPI Clock Schmitt trigger |
| J1 - 8 | 8 | SS/ | DI_PD | SPI Slave Select, active LOW |
| JP1 | 7 | Wire_Mode | S | 3 wire mode or 4 wire mode SPI communication |
| JP2 | 1 | INT_EN/ | DO_OD | Close: enable INT/ output Pin 1 is the AS505x En_INT/ input. Can be used for interrupt daisy chain (see chapter 4.3) |

Table 1: Pin description

| | | | | |
|------------|-------|---------------------------|------|----------------------------|
| Pin types: | DO_OD | digital output open drain | S | supply pin |
| | DO | digital output | DI | digital input |
| | DI_PD | digital input pull-down | DO_T | digital output / tri-state |
| | DI_PU | digital input pull-up | ST | Schmitt-Trigger input |

4 Operation use cases

4.1 One device SPI mode, unidirectional – 3 wire

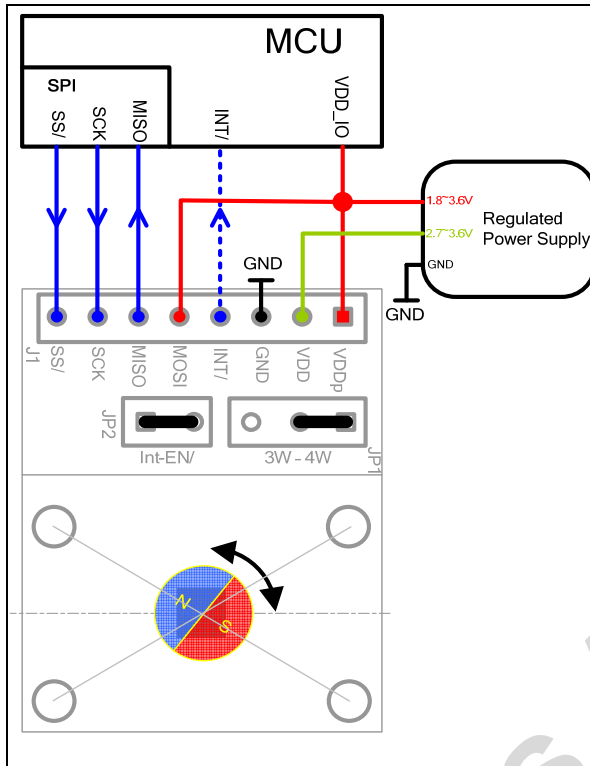

The AS5050-AB can be directly connected to an industry standard SPI port of a microcontroller. The minimum connection requirement for unidirectional communication (angle + alarm values reading) between the microcontroller and the AS5050/AS5055 are MISO, SCK, SS/.

The angle will be read at each 16-bit SPI transfer. See AS5050/AS5055 datasheet register table, register 3FFFh.

This value must be read with a period of 600µs or more in order to get a new angle position.

The INT/ signal can be attached to the microcontroller to indicate that a new angle position has been calculated.

4.2 One device SPI mode, bidirectional – 4 wire

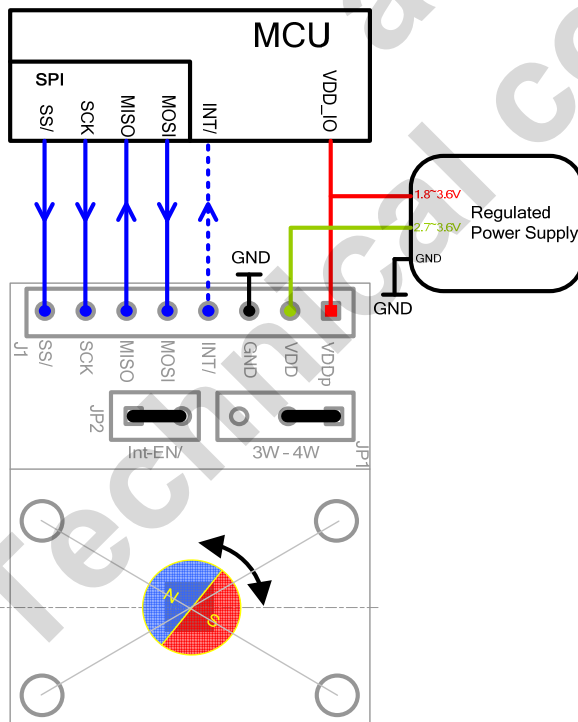

If other registers than only angle value have to be read, or in order to write registers into the AS5050/AS5055, the signal MOSI is necessary.

The INT/ signal can be attached to the microcontroller to indicate that a new angle position has been calculated.

4.3 Multi devices SPI Daisy chain mode

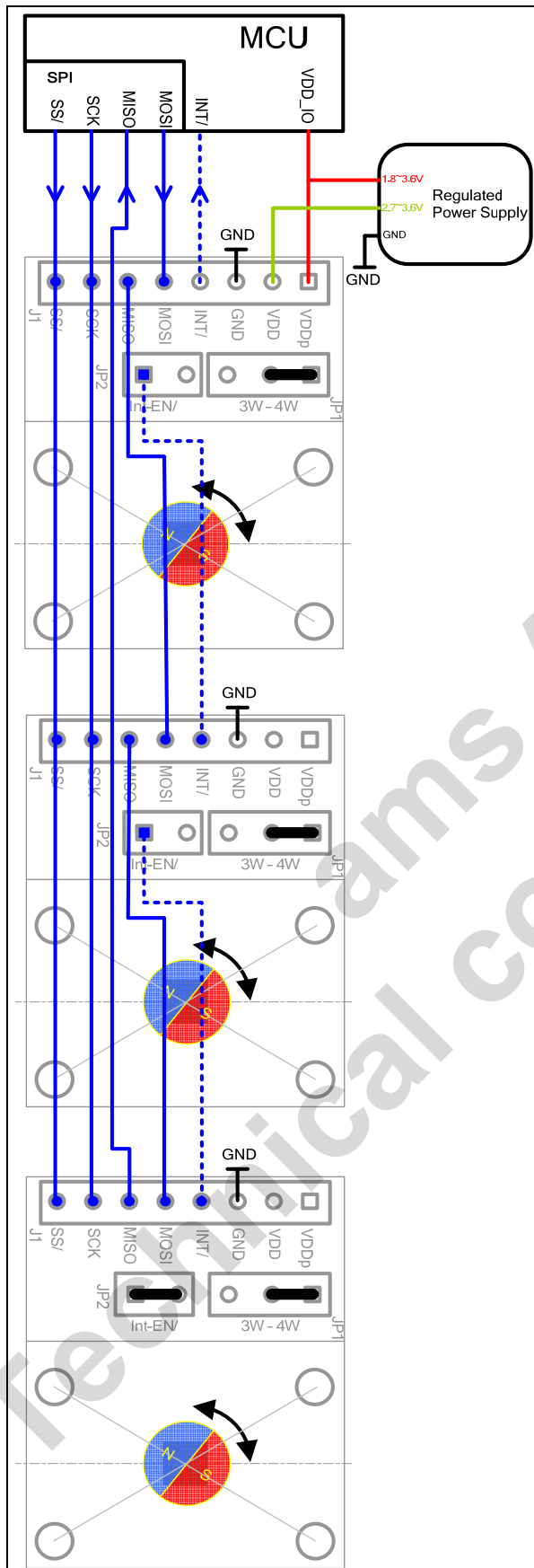

The AS5050/AS5055 can be daisy chained, using 4 wires only for SPI communication.

In this configuration with n x encoders, the sequence will be processed as follow:

- MCU sets SS/ = 0
- MCU shifts n x 16-bit (e.g. READ command FFFFh) through the chain
- MCU sets SS/=1

At that point all the n x encoders have received the READ command FFFFh.

- MCU sets SS/=0
- MCU shifts n x 16-bit (e.g. NOP command 0000h)
- MCU sets SS/=1

At that point the n x 16-bit received on MISO are the n x angle values.

If an interrupt is needed, the signal INT/ can be daisy chained as shown on the diagram on the left. The final INT/ signal connected to the MCU will go LOW only if all the n x encoders INT/ = 0. The n x 16-bit angle readout can be performed here.

5 Firmware coding

The following source code fits the 4-Wire application (chapter 4.2).

The function `void spiReadData()` reads/writes 3 values from the AS5050/AS5055

- Send command READ AGC / Receive value unknown
- Send command READ Angle / Receive value AGC
- Send command NOP (no operation) / Receive value ANGLE

If a READ ANGLE only is necessary in a loop, the procedure can be reduced to one line:

- Send command READ Angle / Receive value Angle (T-1)

The function `static u8 spiCalcEvenParity(ushort value)` is optional, it calculates the parity bit of the 16-bit SPI stream.

```
/*!
*****
* Reads out chip data via SPI interface
*
* This function is used to read out cordic value from chips supporting SPI
* interface.
*****
*/
#define SPI_CMD_READ 0x8000 /*!< flag indicating read attempt when using SPI interface */
#define SPI_REG_DATA 0x7ffe /*!< data register when using SPI */
#define SPI_REG_AGC 0x7ff0 /*!< agc register when using SPI */
#define SPI_REG_CLRERR 0x6700 /*!< clear error register when using SPI */

void spiReadData()
{
    u16 dat; /* 16-bit data buffer for SPI communication */
    ushort angle, agcreg;
    ubyte agc;
    ushort value;
    bit alarmHi, alarmLo;

    /* Send READ AGC command. Received data is thrown away: this data comes from the precedent
command (unknown)*/
    dat = SPI_CMD_READ | SPI_REG_AGC;
    dat |= spiCalcEvenParity(dat);
    spiTransfer((u8*)&dat, sizeof(u16));

    /* Send READ ANGLE command. Received data is the AGC value, from the precedent command */
    dat = SPI_CMD_READ | SPI_REG_DATA;
    dat |= spiCalcEvenParity(dat);
    spiTransfer((u8*)&dat, sizeof(u16));
    agcreg = dat;

    /* Send NOP command. Received data is the ANGLE value, from the precedent command */
    dat = 0x0000; /* NOP command.
spiTransfer((u8*)&dat, sizeof(u16));
angle = dat >> 2;

}

if (((dat >> 1) & 0x1) || ((agcreg >> 1) & 0x1))
{
    /* error flag set - need to reset it */
    dat = SPI_CMD_READ | SPI_REG_CLRERR;
    dat |= spiCalcEvenParity(dat);
    spiTransfer((u8*)&dat, sizeof(u16));
}
else
{
    agc = (agcreg >> 2) & 0x3f; /* AGC value (0..63)
value = (dat >> 2) & 0x3fff; /* Angle value (0..4095 for AS5055)
angle = (value * 360) / 4095; /* Angle value in degree (0..359.9°)
alarmLo = (dat >> 14) & 0x1;
alarmHi = (dat >> 15) & 0x1;

}
}
```

```
/*!
*****
* Calculate even parity of a 16 bit unsigned integer
*
* This function is used by the SPI interface to calculate the even parity
* of the data which will be sent via SPI to the encoder.
*
* \param[in] value : 16 bit unsigned integer whose parity shall be calculated
*
* \return : Even parity
*
*****
*/
static u8 spiCalcEvenParity(ushort value)
{
    u8 cnt = 0;
    u8 i;

    for (i = 0; i < 16; i++)
    {
        if (value & 0x1)
        {
            cnt++;
        }
        value >>= 1;
    }
    return cnt & 0x1;
}
```

6 AS5050 adapter board hardware

6.1 AS5050-AB-1.1 schematics

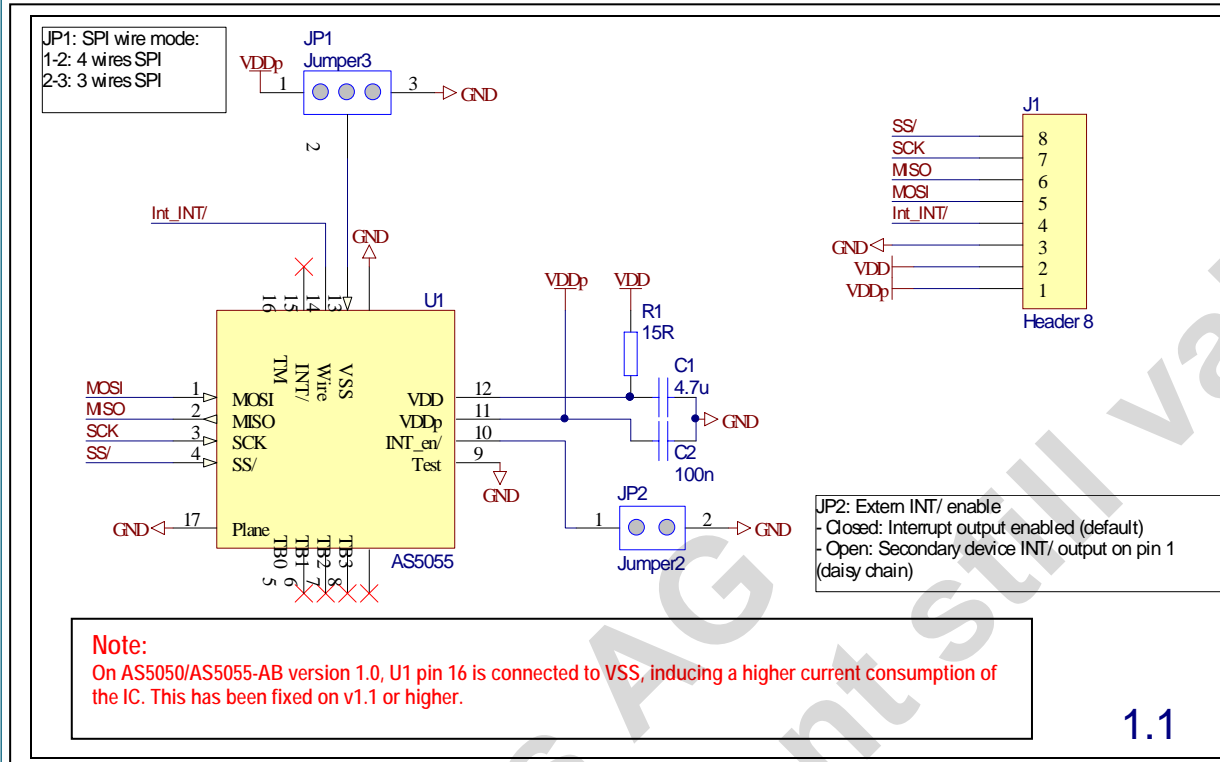

Figure 4: AS5050-AB-1.1 adapterboard schematics

6.2 AS5050-AB-1.1 PCB layout

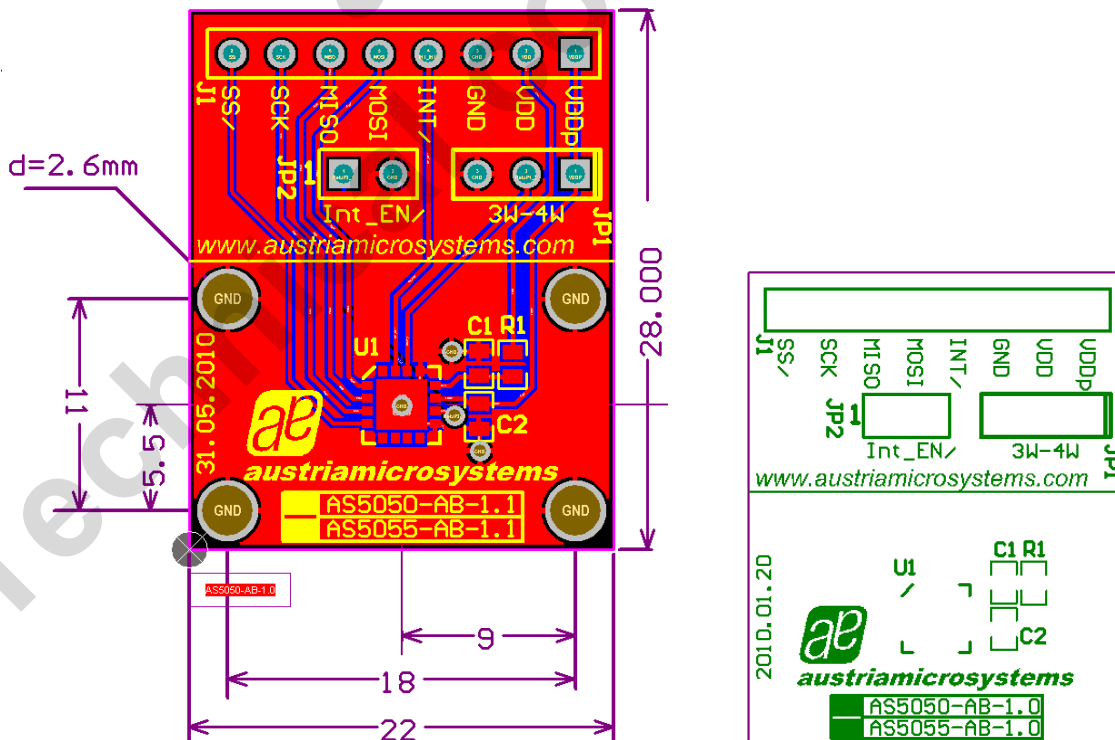

Figure 5: AS5050-AB-1.0 adapter board layout

Table of contents

| | | |
|-----|--|----|
| 1 | VDD General Description | 1 |
| 2 | The AS5050/AS5055 Adapter board | 1 |
| 2.1 | Board description | 1 |
| 2.2 | Mounting the AS5050 adapter board | 2 |
| 3 | AS5050/AS5055 and adapter board pinout | 3 |
| 4 | Operation use cases | 4 |
| 4.1 | One device SPI mode, unidirectional – 3 wire | 4 |
| 4.2 | One device SPI mode, bidirectional – 4 wire | 4 |
| 4.3 | Multi devices SPI Daisy chain mode | 5 |
| 5 | Firmware coding | 6 |
| 6 | AS5050 adapter board hardware | 8 |
| 6.1 | AS5050-AB-1.0 schematics | 8 |
| 6.2 | AS5050-AB-1.0 PCB layout | 8 |
| | Table of contents | 9 |
| | Copyrights | 10 |
| | Disclaimer | 10 |
| | Contact Information | 10 |

Copyrights

Copyright © 1997-2010, austriamicrosystems AG, Schloss Premstaetten, 8141 Unterpremstaetten, Austria-Europe. Trademarks Registered ®. All rights reserved. The material herein may not be reproduced, adapted, merged, translated, stored, or used without the prior written consent of the copyright owner. All products and companies mentioned are trademarks or registered trademarks of their respective companies.

Disclaimer

Devices sold by austriamicrosystems AG are covered by the warranty and patent indemnification provisions appearing in its Term of Sale. austriamicrosystems AG makes no warranty, express, statutory, implied, or by description regarding the information set forth herein or regarding the freedom of the described devices from patent infringement. austriamicrosystems AG reserves the right to change specifications and prices at any time and without notice. Therefore, prior to designing this product into a system, it is necessary to check with austriamicrosystems AG for current information. This product is intended for use in normal commercial applications. Applications requiring extended temperature range, unusual environmental requirements, or high reliability applications, such as military, medical life-support or lifesustaining equipment are specifically not recommended without additional processing by austriamicrosystems AG for each application. The information furnished here by austriamicrosystems AG is believed to be correct and accurate. However, austriamicrosystems AG shall not be liable to recipient or any third party for any damages, including but not limited to personal injury, property damage, loss of profits, loss of use, interruption of business or indirect, special, incidental or consequential damages, of any kind, in connection with or arising out of the furnishing, performance or use of the technical data herein. No obligation or liability to recipient or any third party shall arise or flow out of austriamicrosystems AG rendering of technical or other services.

Contact Information

Headquarters

austriamicrosystems AG
A-8141 Schloss Premstaetten, Austria
Tel: +43 (0) 3136 500 0
Fax: +43 (0) 3136 525 01

For Sales Offices, Distributors and Representatives, please visit:

<http://www.austriamicrosystems.com>