

## Description

The ISL6298EVAL1 provides a complete platform for the evaluation of the ISL6298-2CR3. The on-board 9-bit DIP switch facilitates programming charging current, setting EN input, temperature monitoring status, and so on. The four jumpers can set up input source selection, USB mode selection, and can be used to make other necessary connections.

Assembled in the center square, the components constitute a complete charger solution, demonstrating the space saving advantage of the ISL6298 in limited space applications.

LEDs connected to FAULT and STATUS pins will indicate the normal charging status or fault condition.

On-board jumpers and a DIP switch accommodate different operation conditions for the charger.

## Ordering Information

PART NUMBER	DESCRIPTION
ISL6298EVAL1	Evaluation Board for ISL6298-2CR3

## Features

- 9-bit DIP switch for conveniently setting up charging current, battery thermal status, EN input, and so on
- Different jumpers for input source selection, USB mode selection, and the convenience of current measurement
- Exposed soldering pads connected to STATUS, FAULT, TIME, EN, V2P8 and TEMP functional pins to accommodate experimental testing that need extra connections to those pins
- Board size 3.5 x 2.5 square inches for the convenience of evaluation
- Eight thermal vias in the thermal pad simulating the customers' thermally enhanced environment

## Pinout

ISL6298 3X3 DFN  
TOP VIEW

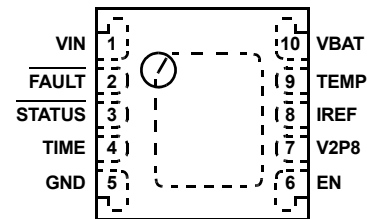

## What is inside

The Evaluation Kit contains:

- ISL6298EVAL1 board
- The ISL6298 Data Sheet
- This ISL6298EVAL1 Application Note

## What is needed

The following instruments will be needed to perform testing:

- Power supplies:
  - 1.PS1: DC 20V/5A,
  - 2.PS2: DC (sinks current) 20V/5A, such as Agilent 6654A
- Electronic load: 20V/5A
- Multimeters
- Function generator
- Oscilloscope
- Cables and wires

## Quick Setup Guide

*Step 1: Switch on bit 4 and bit 7 of the Dip-switch. Leave all other bits off, (See Figure 1.)*

**DO NOT APPLY POWER UNTIL STEP 6**

- Step 1: Connect 5V on VIN.*
- Step 2: Connect 3.7V on VBAT.*
- Step 3: Connect 500mA electronic load on VBAT.*
- Step 4: Verify that no shunts across all jumpers.*
- Step 5: Turn on Power Supplies and electronic load.*
- Step 6: Green LED should be on, indicating normal charging operation.*
- Step 7: If current meter is in series with VIN, it shall read 250mA as the charging current.*

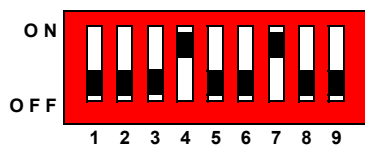

FIGURE 1. INITIAL DIP SWITCH SETTINGS

## DIP Switch Settings

A 9-bit DIP switch is provided to set up voltage, current reference, end-of-charge (EOC) current, and so on. The functionality of the bits are described in Table 1.

TABLE 1. DIP SWITCH PIN DESCRIPTIONS

Bit	Description	ON	OFF	Remark
1	Adjustable TIMEOUT	5 hours 50 mins	3 hours 30 mins	
2				not connected
3	Charger enable/disable	charger disabled	charger enabled	
4	IREF setting 1	Add 125mA	I <sub>CHG</sub> =125mA When both off	
5	IREF setting 2	Add 250mA		
6				not connected
7	TEMP normal	normal		All off simulates battery removal
8	TEMP high	too hot		
9	TEMP low	too cold		

TABLE 2. JUMPER SETTINGS

JUMPER	POSITION	FUNCTION
JP1	USB TO VIN	USB connection
	WALL CUBE TO VIN	Wall adapter connection
JP2	Installed	connect VBAT pin to battery current meter can replace shunt
JP3	not installed	default
	installed	Battery attached to Thermistor at J2
JP4	IREF and V2P8	USB 255mA
	IREF and GND	USB 100mA

### Initial Board Jumper Positioning (Refer to Figure 3)

**JP1** - Selects the VIN pin to be connected to either wall adapter, or to USB connector. If J1 connector is being used, a shunt must be installed across 'WALL CUBE TO VIN', or if J3 (USB) connector is being used a shunt must be installed across 'USB TO VIN'. J1, J3 and JP1 can be ignored if power supply is connected directly to VIN test point, which is directly connected to VIN pin of the IC. A current meter can replace the shunt mentioned above, so as to measure the input current.

**JP2** - Can connect the VBAT pin to the battery. If the J2 connector is being used, a shunt must be installed across JP2. In this case, a current meter can also replace the shunt to measure the VBAT current.

**JP3** - Can connect the TEMP pin to the battery. Usually no shunt is needed for JP3, as the Eval board can simulate various battery thermal conditions. Only when a battery attached with a thermistor is applied on J2 does it become necessary to install a shunt across JP3, and at the same time bit 7, 8, 9 on the DIP switch all need to be turned off.

**JP4** - Selects USB modes: a shunt across IREF and V2P8 will set USB 250mA mode, a shunt across IREF and GND will set USB 100mA mode. When the charge current is programmed by the resistors connected to IREF pin, no shunt should be installed on JP4.

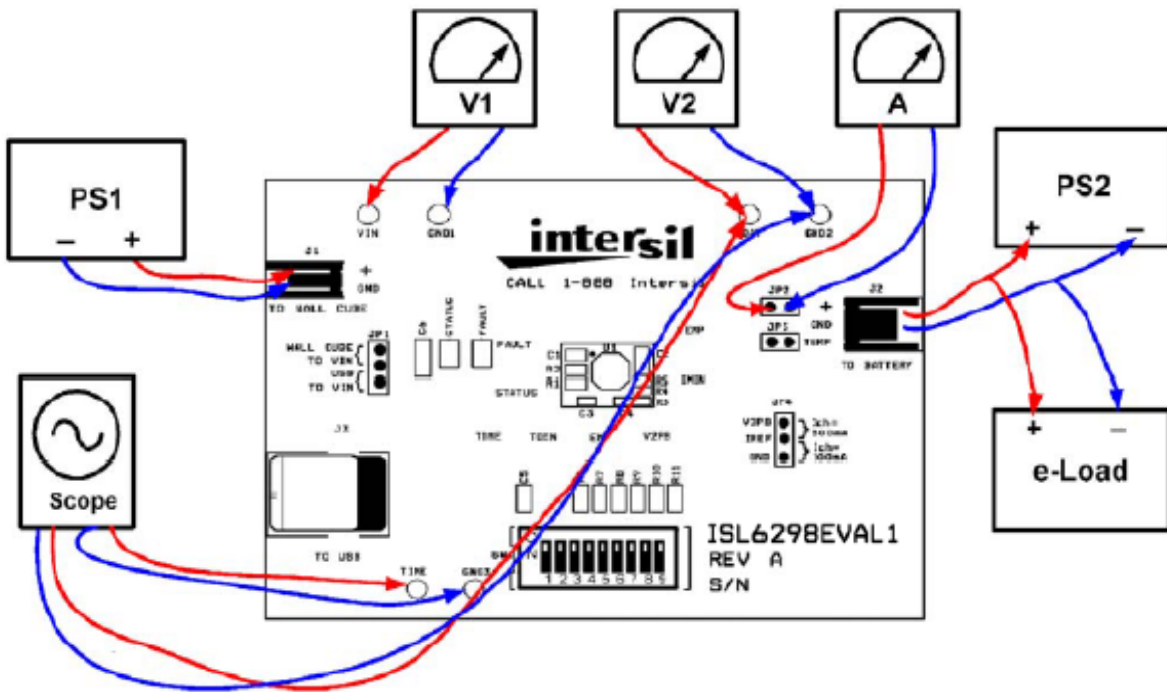

FIGURE 2. CONNECTION OF INSTRUMENTS

# Board Information

## Schematics

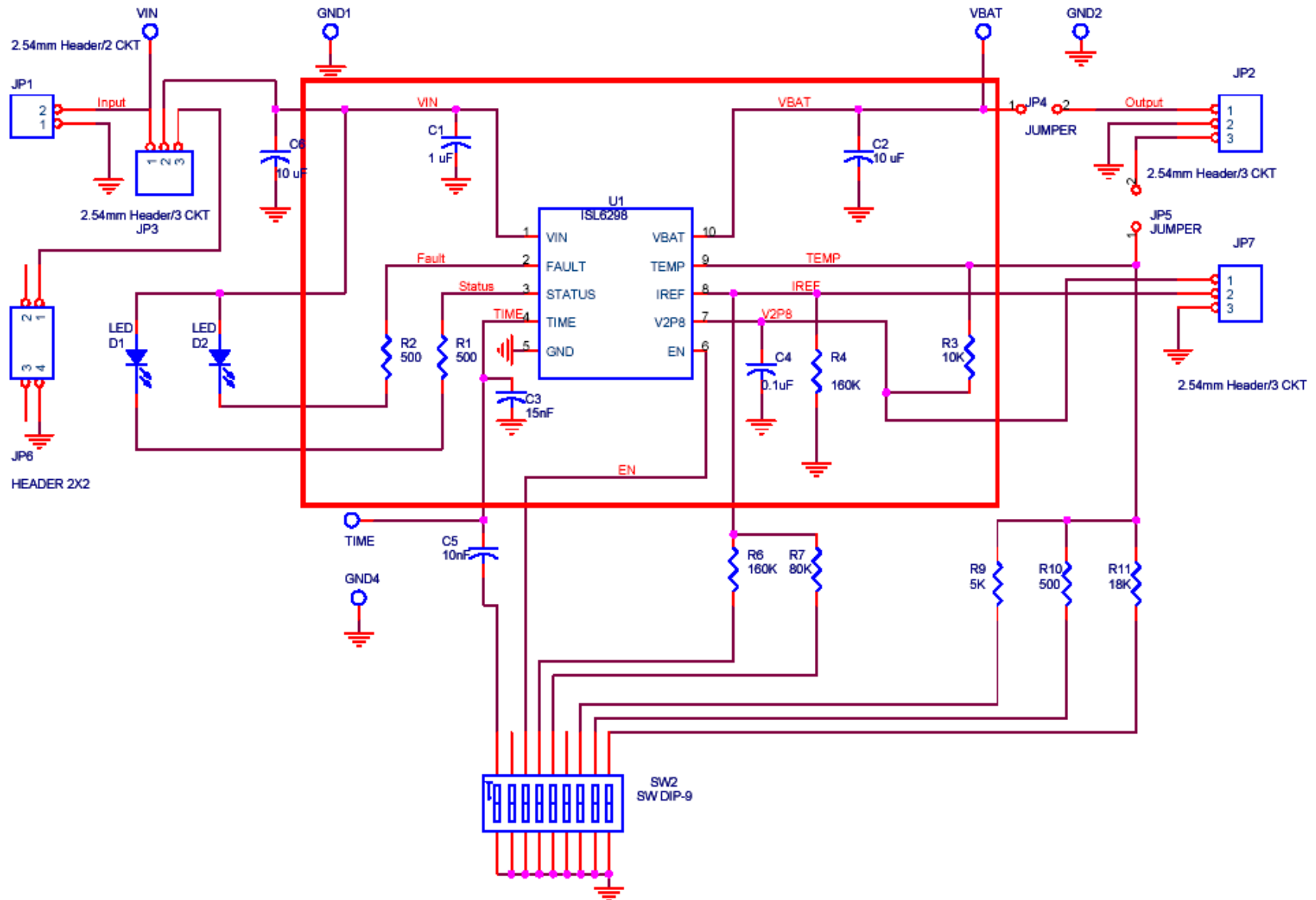

FIGURE 3. BOARD LAYOUT INFORMATION SCHEMATIC

# Application Note 1171

TABLE 3. ISL6298EVAL1 BILL OF MATERIALS

ITEM	QTY	REFERENCE	PART DESCRIPTION	PCB FOOTPRINT	PART NUMBER	VENDOR
1	1	C1	1 $\mu$ F, 6.3V, X5R ceramic cap	0603	0603X105K6R3	Walsin
2	1	C2	10 $\mu$ F/6.3V, Tantalum Cap	2.05 x 1.3 x 1.2	TAJR106M006	AVX
3	1	C3	15nF/16V, X7R ceramic cap	0402	C1005X7R1C153K	TDK
4	1	C4	0.1 $\mu$ F/16V, Y5V ceramic cap	0402	C1005Y5V1C104ZT	TDK
5	1	C5	10nF/16V, X7R Ceramic cap	0805	C1005X7R1C103K	TDK
6	1	C6	10 $\mu$ F/16V, Tantalum Cap	3.2 x 1.6 x 1.6	TAJA106M016	AVX
7	1	D1	Green LED	0805	67-1553-1-ND	DigiKey
8	1	D2	Red LED	0805	67-1552-1-ND	DigiKey
9	2	R1, R2	1K, 5%	0603		Various
10	1	R3	10K, 1%	0603		Various
11	1	R4	160K, 1%	0603		Various
12	1	R6	160K, 1%	0805		Various
13	1	R7	80K, 1%	0805		Various
14	1	R9	5K, 1%	0805		Various
15	1	R10	500, 1%	0805		Various
16	1	R11	18K, 1%	0805		Various
17	1	J1	2.54mm Male Header, 2 ckt (R/A)		A23879-ND	DigiKey
18	1	J2	2.54mm Male Header, 3 ckt (R/A)		A23880-ND	DigiKey
19	2	JP1, JP4	2.54mm Male Header, 3ckt		WM6403-nd	DigiKey
20	2	JP2, JP3	2.54mm Male Header, 2 ckt		WM6402-nd	DigiKey
21	1	J3	USB receptacle, B type		787780-1-ND	DigiKey
22	1	SW1	DIP Switch, 9 Pos, SMT		CKN1323-ND	DigiKey
23	1	U1	Single-Cell Li-ion Battery Charger	10-pin, 3X3 DFN	ISL6298	Intersil
24	6	VIN, VBAT, TIME, GND1, GND2, GND3	Test Point		5002K-ND	DigiKey

## PCB Layout

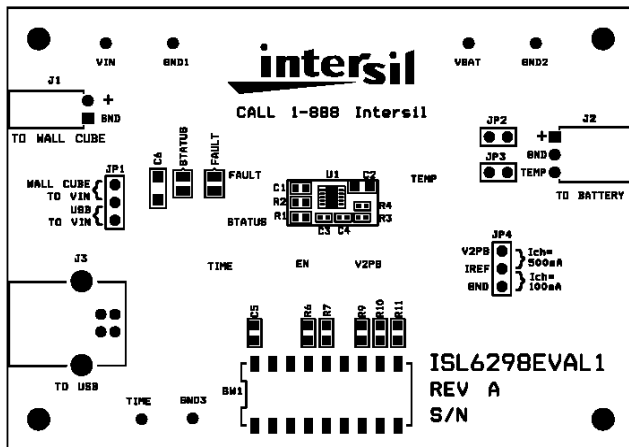

SILK SCREEN LAYER

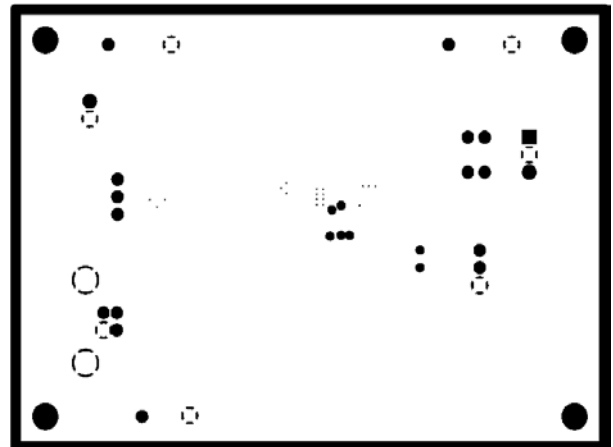

INTERNAL (LAYER 2, GND)

PCB Layout (Continued)

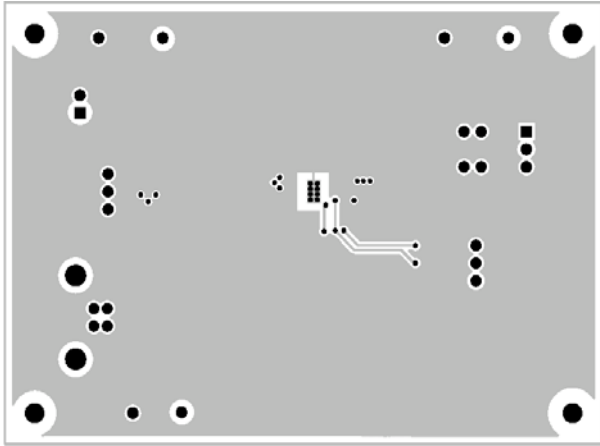

BOTTOM (LAYER 4, GND)

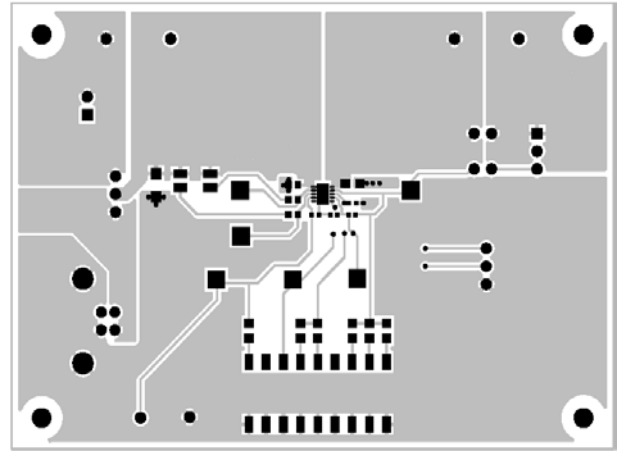

TOP (LAYER 1, SIGNAL)

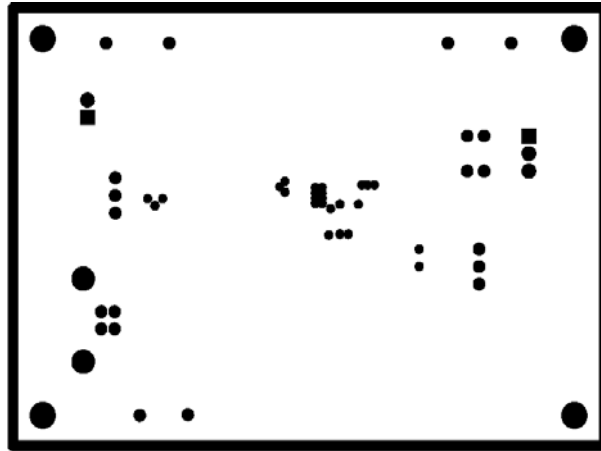

INTERNAL (LAYER 3, FLOATING)

Intersil Corporation reserves the right to make changes in circuit design, software and/or specifications at any time without notice. Accordingly, the reader is cautioned to verify that the Application Note or Technical Brief is current before proceeding.

For information regarding Intersil Corporation and its products, see [www.intersil.com](http://www.intersil.com)