

9 TO 25 CONTACTS : 1.84^{+0.1}/₀
 31 TO 51 CONTACTS : 3^{+0.1}/_{-0.1}

PART No.	CODE No.	NUMBER OF CONTACTS	A	B	C	D	E	F
DF9B- 9P-1V(69)	CL540-0134-7-69	9	10.1	8.3	6.6	3	4	8.4
DF9B-11P-1V(69)	CL540-0135-0-69	11	11.1	9.3	7.6	4	5	9.4
DF9B-13P-1V(69)	-	13	12.1	10.3	8.6	5	6	10.4
DF9B-15P-1V(69)	CL540-0137-5-69	15	13.1	11.3	9.6	6	7	11.4
DF9B-17P-1V(69)	CL540-0138-8-69	17	14.1	12.3	10.6	7	8	12.4
DF9B-19P-1V(69)	CL540-0248-6-69	19	15.1	13.3	11.6	8	9	13.4
DF9B-21P-1V(69)	CL540-0140-0-69	21	16.1	14.3	12.6	9	10	14.4
DF9B-23P-1V(69)	-	23	17.1	15.3	13.6	10	11	15.4
DF9B-25P-1V(69)	-	25	18.1	16.3	14.6	11	12	16.4
DF9B-31P-1V(69)	CL540-0144-0-69	31	21.1	19.3	17.6	14	15	19.4
DF9B-41P-1V(69)	CL540-0221-0-69	41	26.1	24.3	22.6	19	20	24.4
DF9B-51P-1V(69)	CL540-0146-6-69	51	31.1	29.3	27.6	24	25	29.4

NOTES 1 : LEAD CO-PLANARITY INCLUDE REINFORCED METAL FITTINGS SHALL BE 0.1mm MAX.
 ② CAV NO. IS INDICATED IN APPROX POSITION SHOWN.
 ③ 9 TO 25 CONTACT CONNECTORS HAVE ONE LOCK AT CENTER OF HOUSING.
 31 TO 51 CONTACT CONNECTORS HAVE TWO LOCKS AS PER DRAWING.

NO.	MATERIAL	FINISH . REMARKS	NO.	MATERIAL	FINISH . REMARKS
3	BRASS	SURFACE:TIN PLATED(REFLOW FINISH)1μm min UNDER PLATING:COPPER 0.3μm min	8	PS	REINFORCEMENT COLLAR
2	PHOSPHOR BRONZE	CONTACT AREA:GOLD PLATED 0.2μm min LEAD AREA:TIN PLATED 1μm min UNDER PLATING:NICKEL 0.3μm min	7	PS	BLACK(PLASTIC REEL)
			6	POLYIMIDE	BROWN(HEAT-RESISTANCE TAPE)
			5	POLYESTER	CLEAR(COVER TAPE)
1	POLYAMIDE	BEIGE, UL94V-0	4	PS	CLEAR(EMBOSSD CARRIER TAPE)

UNITS	SCALE	COUNT	DESCRIPTION OF REVISIONS	DESIGNED	CHECKED	DATE
mm	5 : 1	△				

APPROVED : KH. IKEDA	11.12.28	DRAWING NO.	EDC3-341299-03
CHECKED : AR. TAKAHASHI	11.12.28	PART NO.	DF9B-*P-1V(69)
DESIGNED : SH. HOSODA	11.12.27	CODE NO.	CL540-
DRAWN : KR. AJITO	11.12.27		

Apr.1.2017 Copyright 2017 HIROSE ELECTRIC CO., LTD. All Rights Reserved.

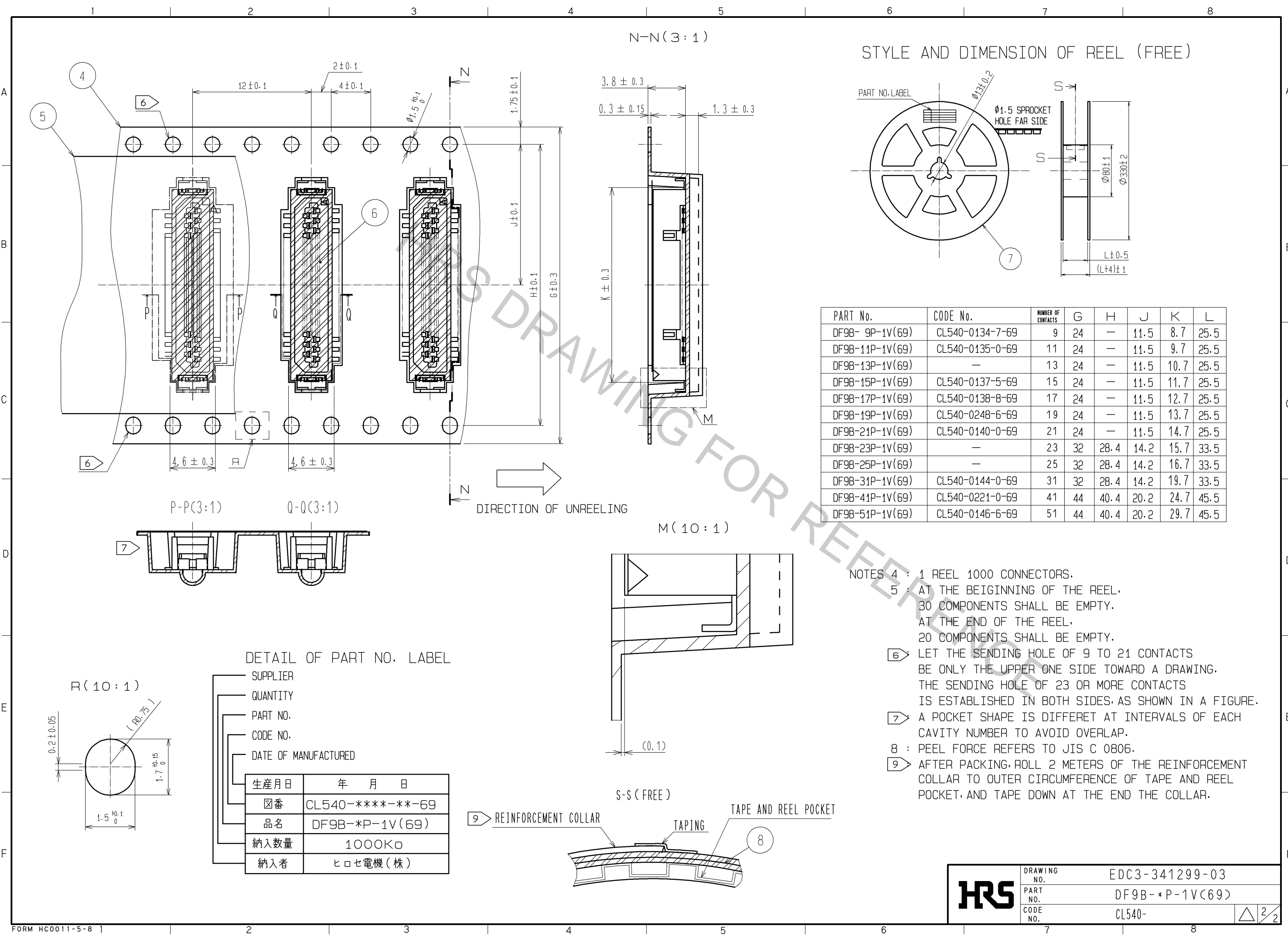

PART No.	CODE No.	NUMBER OF CONTACTS	G	H	J	K	L
DF9B-9P-1V(69)	CL540-0134-7-69	9	24	—	11.5	8.7	25.5
DF9B-11P-1V(69)	CL540-0135-0-69	11	24	—	11.5	9.7	25.5
DF9B-13P-1V(69)	—	13	24	—	11.5	10.7	25.5
DF9B-15P-1V(69)	CL540-0137-5-69	15	24	—	11.5	11.7	25.5
DF9B-17P-1V(69)	CL540-0138-8-69	17	24	—	11.5	12.7	25.5
DF9B-19P-1V(69)	CL540-0248-6-69	19	24	—	11.5	13.7	25.5
DF9B-21P-1V(69)	CL540-0140-0-69	21	24	—	11.5	14.7	25.5
DF9B-23P-1V(69)	—	23	32	28.4	14.2	15.7	33.5
DF9B-25P-1V(69)	—	25	32	28.4	14.2	16.7	33.5
DF9B-31P-1V(69)	CL540-0144-0-69	31	32	28.4	14.2	19.7	33.5
DF9B-41P-1V(69)	CL540-0221-0-69	41	44	40.4	20.2	24.7	45.5
DF9B-51P-1V(69)	CL540-0146-6-69	51	44	40.4	20.2	29.7	45.5

- NOTES
- 4 : 1 REEL 1000 CONNECTORS.
 - 5 : AT THE BEIGINNING OF THE REEL, 30 COMPONENTS SHALL BE EMPTY. AT THE END OF THE REEL, 20 COMPONENTS SHALL BE EMPTY.
 - 6 : LET THE SENDING HOLE OF 9 TO 21 CONTACTS BE ONLY THE UPPER ONE SIDE TOWARD A DRAWING. THE SENDING HOLE OF 23 OR MORE CONTACTS IS ESTABLISHED IN BOTH SIDES, AS SHOWN IN A FIGURE.
 - 7 : A POCKET SHAPE IS DIFFERET AT INTERVALS OF EACH CAVITY NUMBER TO AVOID OVERLAP.
 - 8 : PEEL FORCE REFERS TO JIS C 0806.
 - 9 : AFTER PACKING, ROLL 2 METERS OF THE REINFORCEMENT COLLAR TO OUTER CIRCUMFERENCE OF TAPE AND REEL POCKET, AND TAPE DOWN AT THE END THE COLLAR.

DETAIL OF PART NO. LABEL

- SUPPLIER
- QUANTITY
- PART NO.
- CODE NO.
- DATE OF MANUFACTURED

生産月日	年 月 日
図番	CL540-****-**-69
品名	DF9B-*P-1V(69)
納入数量	1000K□
納入者	ヒロセ電機(株)

HRS	DRAWING NO.	EDC3-341299-03
	PART NO.	DF9B-*P-1V(69)
	CODE NO.	CL540-